

# OWNER'S MANUAL

## MINI CRANES MODEL FPG, CJIB, TJIB

### Contents

Safety Precautions .....	1	Assembly Instructions (Model TJIB) .....	4
Receiving Instructions .....	1	Inspection Instructions .....	5
Warranty .....	1	Testing Instructions .....	6
Assembly Instructions (Model CJIB) .....	2	Parts List (Model FPG) .....	7
Assembly Instructions (Model FPG) .....	3	Warning Label Identification .....	8

### SAFETY PRECAUTIONS

**Read owner's manual completely before operating unit!**

- Never exceed the maximum capacity printed on top beam! This capacity includes the weight of hoist and trolley too.
- Check for damage and be sure all hardware is tight before each use.
- Never move or load unless both height adjustment pins are fully inserted.
- Stand clear of load while loading and unloading.
- Always operate crane on a level concrete or equal surface to insure stability.
- Never push crane or adjust height when loaded.
- Never stand under load.
- Keep clear of electrical wires or any other electrical equipment.
- Make sure all operator safety labels are in place (p.7).

### RECEIVING INSTRUCTIONS

Every unit is thoroughly inspected prior to shipment. However, it is possible that the unit may incur damage during transit. If damage is noticed when unloading, make a note of it on the **BILL OF LADING**. Remove all packing and strapping material, then inspect the unit again for damage. **IF DAMAGE IS EVIDENT, FILE A CLAIM WITH THE CARRIER IMMEDIATELY!**

### WARRANTY

This product is warranted for 90 DAYS from date of purchase to be free of manufacturing defects in material and workmanship. The manufacturer's obligation hereunder is limited to repairing such products during the warranty period, provided the product is sent prepaid back to the factory.

This warranty does not cover normal wear of parts or damage resulting from any of the following: negligent use or misuse of the product, use or application contrary to installation instructions, or disassembly, repair or alteration by any person prior to authorization from a factory representative.

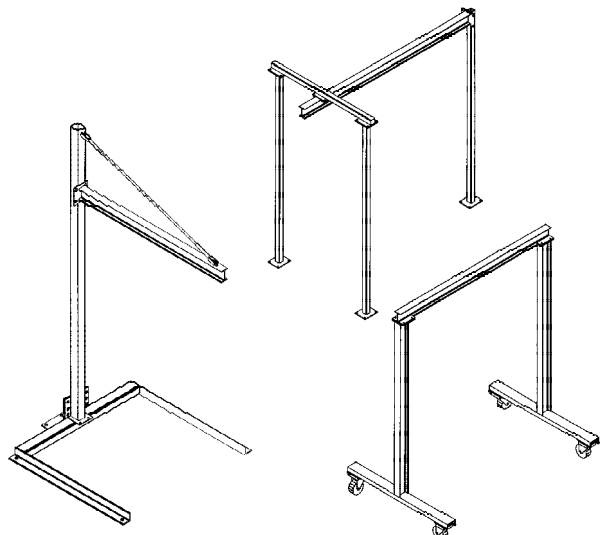

**MINI CRANES  
MODEL FPG, CJIB, TJIB**

ENGLISH

FRANCOIS

FRANCOIS

# ASSEMBLY INSTRUCTIONS - Mini Overhead Cantilever Jib (Model CJIB)

## INSTALLING UPRIGHT & TOP BEAM

- 1.) Attach vertical tubing to base using bolts specified on diagram.
- 2.) Attach top beam to vertical tubing using bolts per diagram. Make sure the bracket on the opposite end of the clamp is facing up.
- 3.) Attach the rod to the top beam and vertical tubing using pins supplied. Check beam levelness after unit base is lagged to floor at 6 places. If beam requires leveling use turn buckles on ends of tie rod. Floor must be smooth and level.

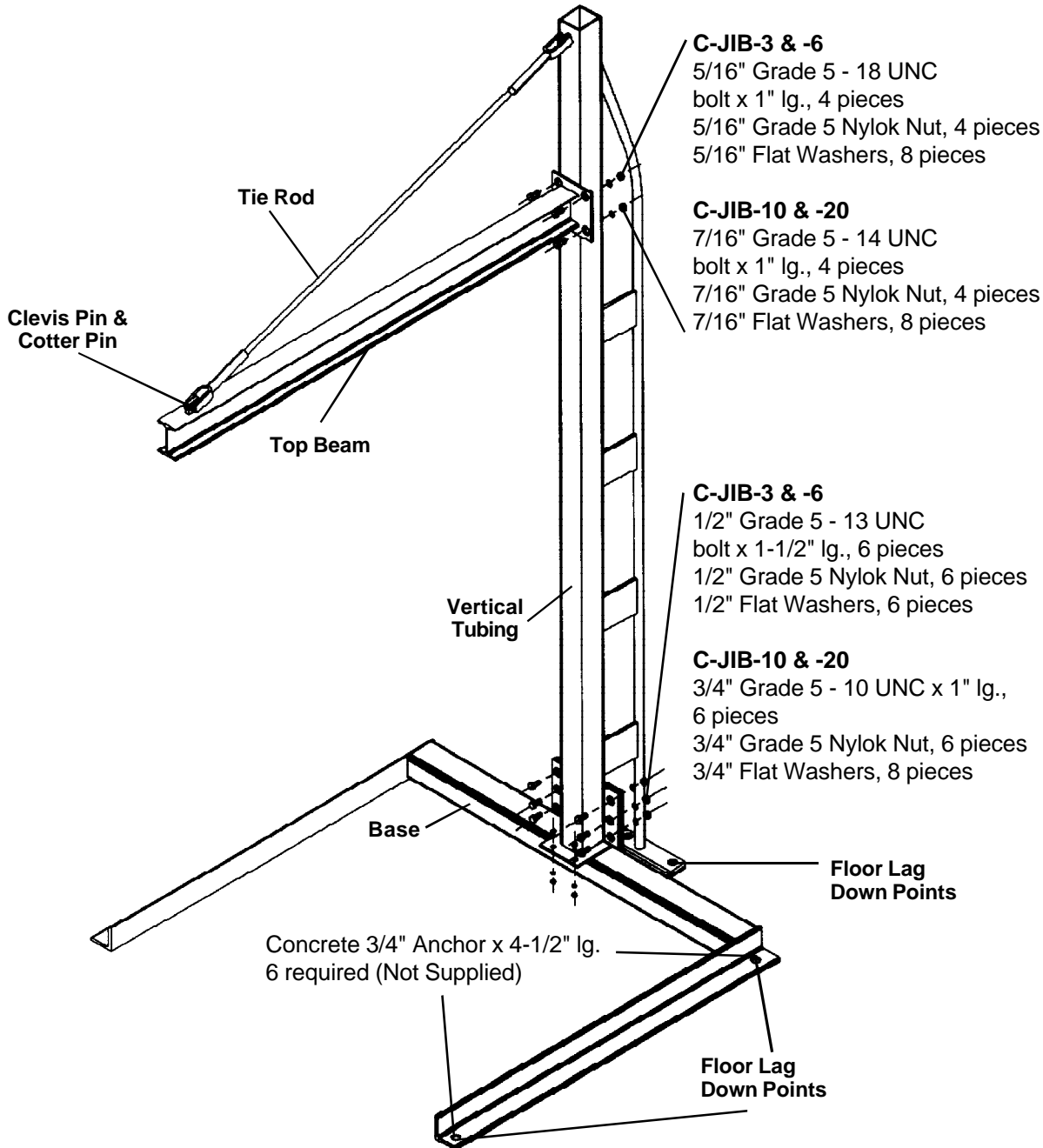

## ASSEMBLY INSTRUCTIONS - Work Area Portable Gantry (Model FPG)

### Step 1 - INSTALLING UPRIGHT & TOP BEAM

- 1.) Lay the gantry base frame on its side and position vertical uprights with holes to base plate.
- 2.) Place 1/2" - 13 structural bolts through the 4 holes in the base with the nuts and washers on the back side.  
**NOTE: Torque bolts to 50-52 ft./lbs.**
- 3.) Attach clamp plates to top plates on both leg assemblies using the 1/2" - 13 structural bolts, nuts and washers leaving them untightened.  
**Note: Torque spec. 1/2" bolts is 50-52 ft./lbs.**

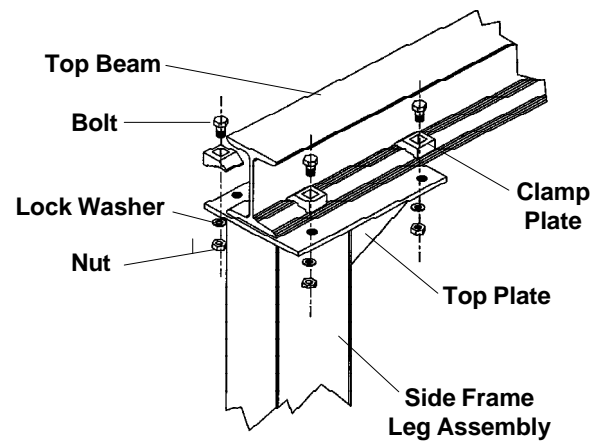

### STEP 2 - INSTALLING CASTERS

- 1.) Two 5" diameter casters are to be installed to each end of the leg assemblies.
- 2.) Place the caster base plate into the caster pad bracket located on the bottom of the leg assemblies.
- 3.) Insert 3/8" - 16 UNC x 5" long carriage bolt through the square hole in the caster pad to hold the caster in place.
- 4.) Place the 3/8" - 16 UNC lock nut on each bolt and tighten securely.

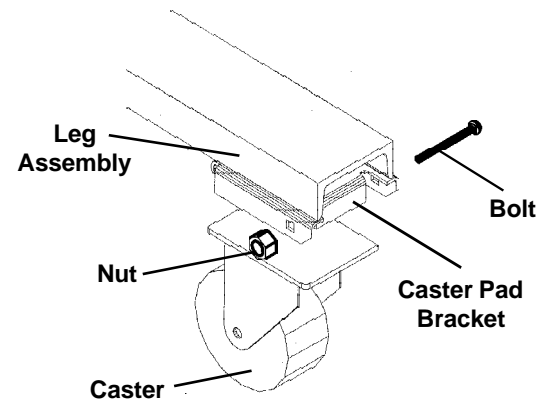
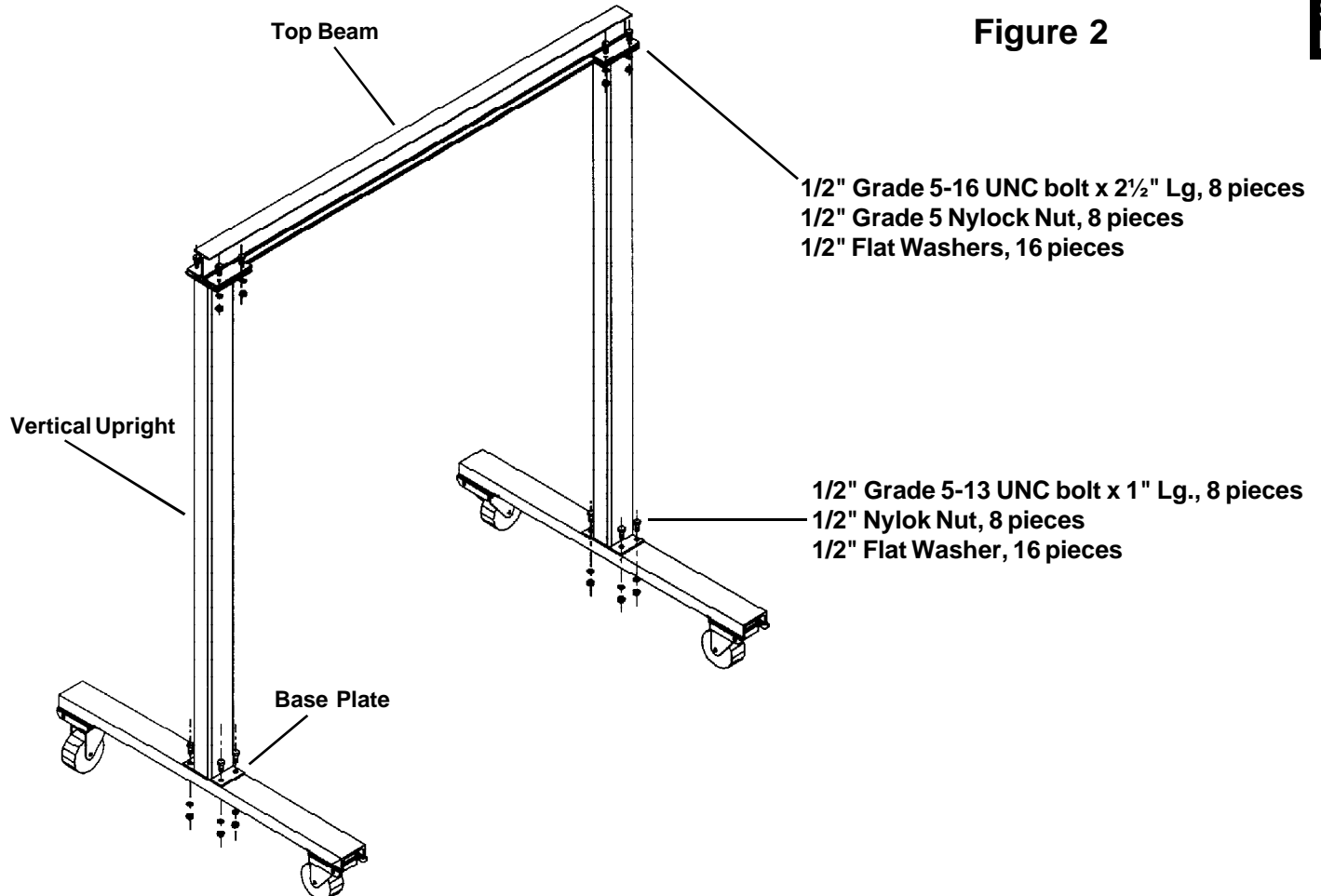
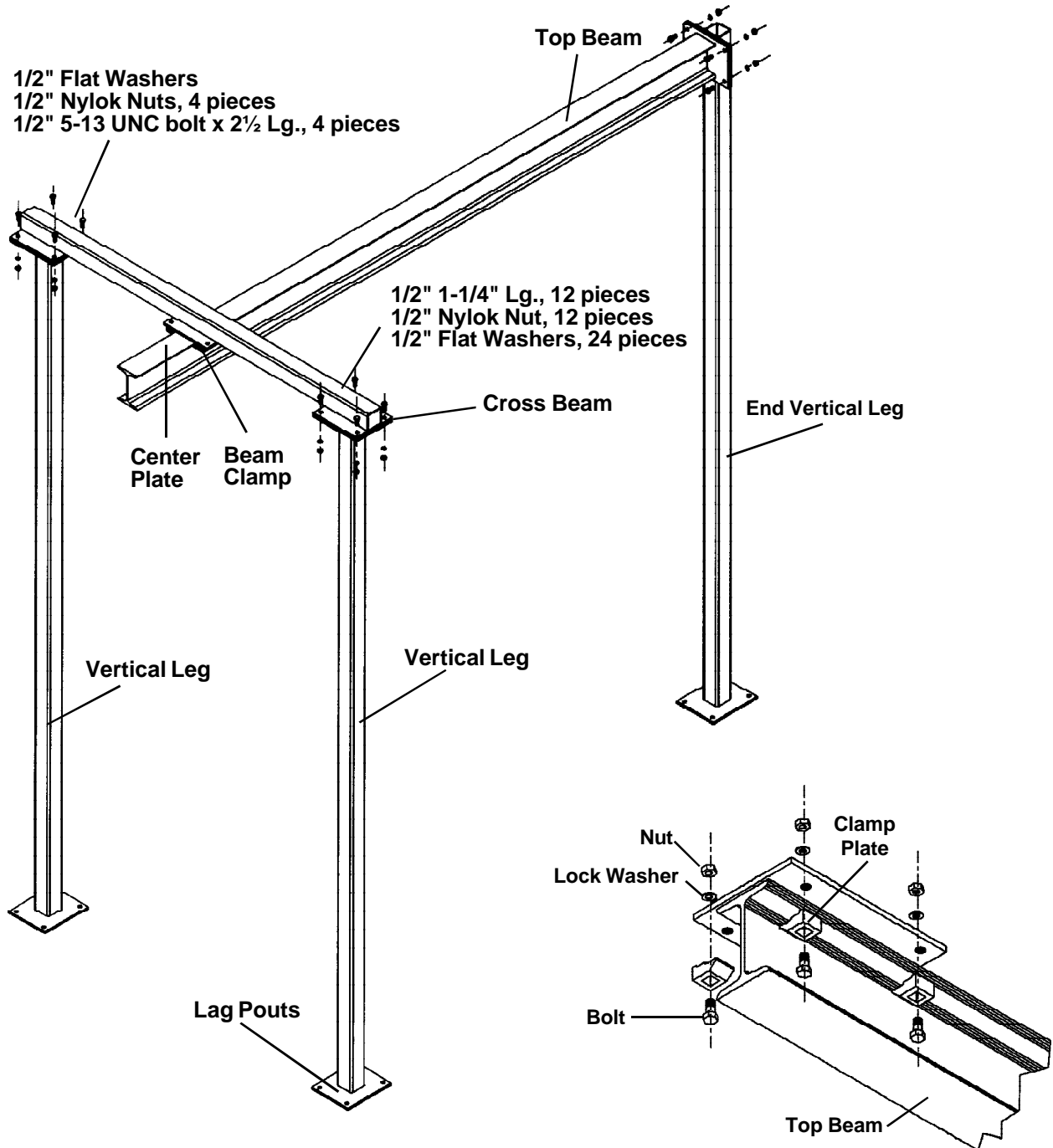

Figure 2



## ASSEMBLY INSTRUCTIONS - Extra Travel Tri-Post Jib (Model TJIB)

- 1.) Take the two legs with the plates placed on top of the ends of the vertical legs and lay them out on the floor.
- 2.) Lay the crossbeam up to the two vertical legs and insert 1/2" structural bolts through the 4 holes per leg. Place a flat washer on each side and use the 1/2" nut on the bottom side.  
**NOTE: Torque specs. to 1/2" bolt is 50-52 ft./lbs.**
- 3.) Install the beam clamps on the center plate of the crossbeam and use the 1/2" structural bolts with a 1/2" flat washer and 1/2" nut. Leave these plates untightened.
- 4.) Attach the top beam to the end vertical leg (has the bracket welded on the side) by using the 1/2" structural bolts, 1/2" flat washer on both sides, and the 1/2" nut.
- 5.) Stand up both sections and slide the top beam through the beam clamps and set the desired overhang on the end (do not exceed two feet). Tighten the (4) 1/2" bolts on the beam clamps. **Note: Torque spec. 1/2" bolts is 50-52 ft./lbs.**
- 6.) Fasten all legs to the floor by placing lag bolts through the floor brackets. Use 1/2" concrete lag bolts. Do not use this unit until it is lagged to the floor.



---

## INSPECTION INSTRUCTIONS

Per OSHA Regulations **1910.179** and American Society of Mechanical Engineers (A.S.M.E.) **B30.20 "Overhead Lifting Devices."**, all gantry cranes should have an:

1910.179(j)(1)(i) Initial inspection - Prior to initial use all new and altered cranes shall be inspected to insure compliance.

Besides that, for gantry cranes in regular service, there are two general classifications of inspections based upon the intervals at which the inspection should be performed. The intervals in turn are dependent upon the nature of the critical components of the crane and the degree of their exposure to wear, deterioration, or malfunction. The two general classifications are herein designated as "frequent" and "periodic" with respective intervals between inspections as defined below:

1910.179(j)(1)(ii)(a) Frequent inspection - Daily to monthly intervals.

1910.179(j)(1)(ii)(b) Periodic inspection - 1 to 12 month intervals.

### **1910.179(j)(2) Frequent Inspection**

The following items shall be inspected for defects at intervals as defined above or as specifically indicated, including observation during operation for any defects which might appear between regular inspections. All deficiencies such as listed shall be carefully examined and determination made as to whether they constitute a safety hazard:

- All functional operating mechanisms for maladjustment interfering with proper operation. Daily.
- Hooks with deformation or cracks. Visual inspection daily; monthly inspection with a certification record which includes the date of inspection, the signature of the person who performed the inspection and the serial number, or other identifier, of the hook inspected.
- Hoist chains, including end connections, for excessive wear, twist, distorted links interfering with proper function, or stretch beyond manufacturer's recommendations. Visual inspection daily; monthly inspection with a certification record which includes the date of inspection, the signature of the person who performed the inspection and an identifier of the chain which was inspected.
- All functional operating mechanisms for excessive wear of components.
- Rope reeving for noncompliance with manufacturer's recommendation.

### **1910.179(j)(3) Periodic Inspection**

Complete inspections of the crane shall be performed at intervals as generally defined above, depending upon its activity, severity of service, and environment, or as specifically indicated below. These inspections shall include the requirements of the frequent inspection stated above and in addition, the following items. All deficiencies such as listed shall be carefully examined and determination made as to whether they constitute a safety hazard:

- Deformed, cracked, or corroded members.
- Loose bolts or rivets.
- Cracked or worn sheaves and drums.
- Worn, cracked or distorted parts such as pins, bearings, shafts, gears, rollers, locking and clamping devices.
- Excessive wear on brake system parts, linings, pawls, and ratchets.
- Load, wind, and other indicators over their full range, for any significant inaccuracies.
- Gasoline, diesel, electric, or other powerplants for improper performance or noncompliance with applicable safety requirements. (IF APPLICABLE)
- Excessive wear of chain drive sprockets and excessive chain stretch.

---

## TESTING INSTRUCTIONS

OSHA also requires two classifications of testing to be performed [per OSHA Regulations **1910.179(k)**]. These two testings are:

1910.179(k)(1) Operational tests

1910.179(k)(2) Rated load test

### **1910.179(k)(1) Operational Tests**

- (i) Prior to initial use all new and altered cranes shall be tested to insure compliance with this section including the following functions:
  - (a) Hoisting and lowering.
  - (b) Trolley travel.
  - (c) Bridge travel.
  - (d) Limit switches, locking and safety devices.
- (ii) The trip setting of hoist limit switches shall be determined by tests with an empty hook traveling in increasing speeds up to the maximum speed. The actuating mechanism of the limit switch shall be located so that it will trip the switch, under all conditions, in sufficient time to prevent contact of the hook or hook block with any part of the trolley.

### **1910.179(k)(2) Rated Load Test**

Test loads shall not be more than 125 percent of the rated load unless otherwise recommended by the manufacturer. The test reports shall be placed on file where readily available to appointed personnel.

**REFER TO OSHA'S STANDARD 1910.179 FOR COMPLETE INFORMATION ON  
OVERHEAD & GANTRY CRANE DEFINITIONS, GENERAL REQUIREMENTS,  
HOISTING EQUIPMENT, MAINTENANCE, ROPE INSPECTION,  
HANDLING OF THE LOAD, AND  
OTHER REQUIREMENTS.**

For OSHA publications, including informational materials  
on standards and regulations, please contact  
OSHA's Publications Office,  
200 Constitution Avenue, N.W., Room N3101,  
Washington, DC20210,  
(202) 219-4667; (202) 219-9266(fax).

**ALSO REFER TO AMERICAN SOCIETY OF MECHANICAL ENGINEERS (A.S.M.E.)  
B30.20 "OVERHEAD LIFTING DEVICES."**

For copies of A.S.M.E. B30.20  
please contact  
American Society of Mechanical Engineers  
Order Department 1-800-THE-ASME

# Mini Overhead Cantilever Jib MODEL - FPG

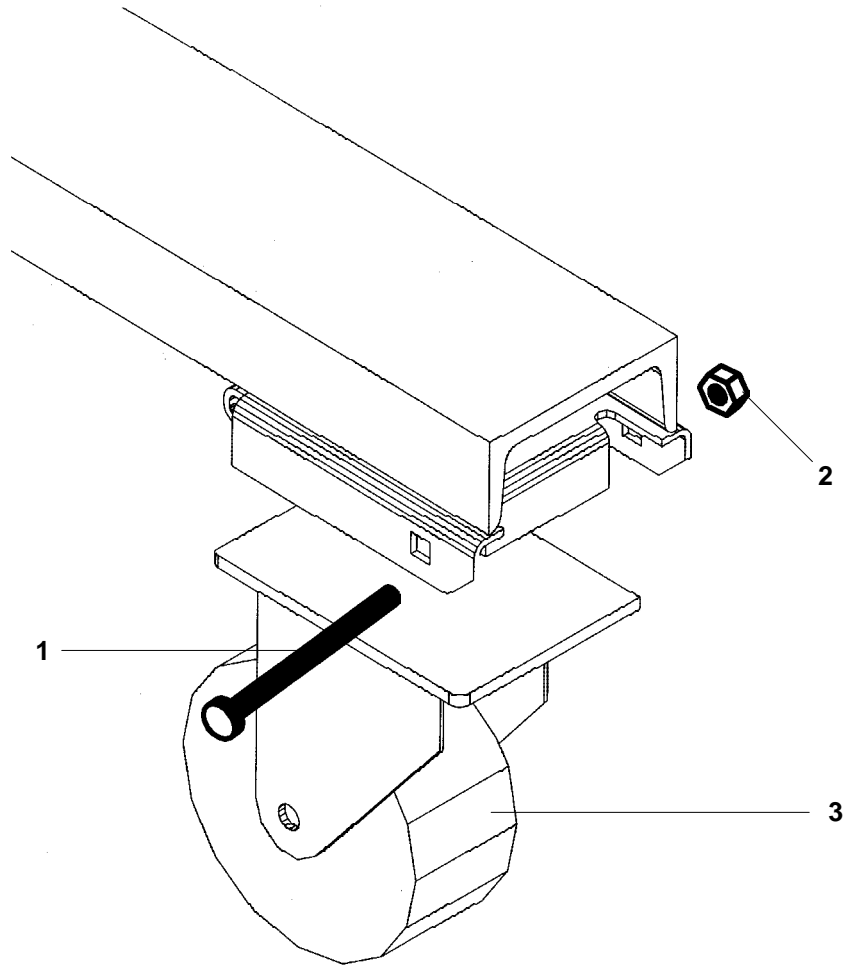

## PARTS IDENTIFICATION

KIT NO.	ITEM NO.	DESCRIPTION	ENGINEER NO.	PART NO.	QTY
A	1	Bolt, 3/8"-16 x 5"	21373	FPG-BLT	4
A	2	Nut, 3/8"-16	37024	FPG-NUT	4
	3	Wheel, Caster Kit	16-132-062	JIB-WHEEL-KITA	4

a/k Available only with purchase of kit

# WARNING LABEL IDENTIFICATION

MAKE SURE ALL WARNING LABELS ARE IN PLACE!

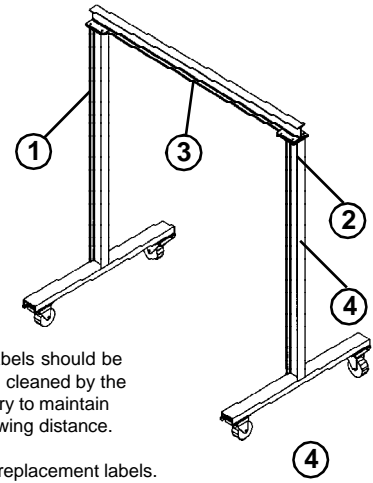
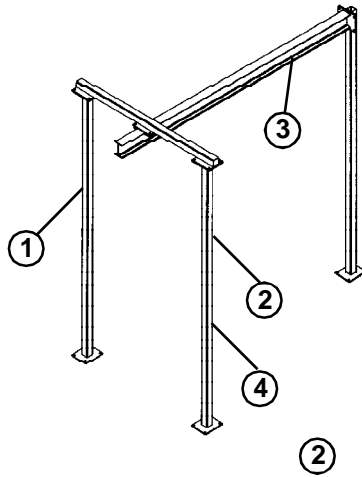
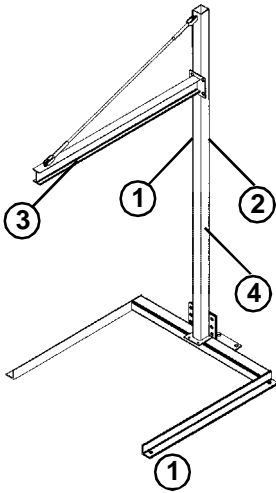

\* Product safety signs or labels should be periodically inspected and cleaned by the product users as necessary to maintain good legibility for safe viewing distance. ANSI 535.4 (10.21)  
Contact manufacturer for replacement labels.

<b>⚠ DANGER</b>
<p>This unit conducts electricity <b>KEEP CLEAR OF POWER LINES!</b> Do not let unit make contact with wires or any other electrical equipment. <b>NEVER</b> stand under load <b>NEVER</b> push unit or adjust height when loaded.</p>
<b>⚠ PELIGRO</b>
<p>Esta unidad es conductora de electricidad <b>MANTENGA ALEJADO DE ALAMBRES ELÉCTRICOS!</b> No deje que la unidad haga contacto con alambres eléctricos u otro equipo eléctrico. <b>NUNCA</b> se ponga de pie bajo la unidad. <b>NUNCA</b> empuje la unidad cargada o ajuste la altura.</p>
<b>⚠ DANGER</b>
<p>Cette unité conduit de l'électricité <b>RESTER À L'ÉCART DES LIGNES ÉLECTRIQUES!</b> Ne pas mettre l'unité en contact avec des fils électriques ou tout autre équipement électrique. <b>NE JAMAIS</b> se tenir sous le chargement. <b>NE JAMAIS</b> pousser l'unité ou ajuster la hauteur lorsque l'unité est chargée.</p>
<p>T &amp; S EQUIPMENT • ANGOLA, IN 46703 (219) 665-9521 <b>255</b></p>

<b>⚠ WARNING</b>
<b>CRANE INSPECTION</b>
<p>This lifter was built in accordance with our interpretations of A.S.M.E. B30.20 "Overhead Lifting Devices" and 49 CFR 1910.179 "Overhead &amp; Gantry Cranes."</p> <p>Prior to initial use, all new, modified or repaired lifters need to be load tested not more than 125% of the rated load. At least once per year, OSHA requires a complete inspection of this Gantry Crane. Refer to 49 CFR 1910.179 (J)(3). Visual inspection should be conducted periodically depending upon frequency of usage. If this lifter shows any deficiencies, corrections shall be made of the unit immediately or it shall be taken out of use.</p> <p>Thoroughly read A.S.M.E. Code B30.20 "Overhead Lifting Devices" and 49 CFR 1910.179 "Overhead &amp; Gantry Cranes" for complete information.</p> <p>Copies of A.S.M.E. B30.20 can be obtained from <b>American Society of Mechanical Engineers</b> Order Department 1-800-THE-ASME</p> <p>Copies of 49 CFR 1910.179 can be obtained from OSHA's Publications Office (202)219-4667</p>
<b>⚠ AVISO</b>
<b>INSPECCIÓN DE LA GRÚA</b>
<p>Este elevador ha sido construido en acuerdo con nuestra interpretación del A.S.M.E. B30.20 "Aparatos de elevación" y 49 CFR 1910.179 "Elevación de grúas."</p> <p>Antes del uso inicial, todos los elevadores nuevos, modificados o reparados deben de ser probados con una carga que no exceda el 125% de la capacidad de carga. Como mínimo una vez al año, OSHA requiere una inspección completa de esta grúa. Referirse a 49 CFR 1910.179 (J)(3). Una inspección visual se debe de hacer periódicamente dependiendo de la frecuencia de uso. Si este elevador tiene alguna deficiencia, se debe de corregir inmediatamente o se debe de retirar del uso.</p> <p>Lea completamente el Código A.S.M.E. Code B30.20 "Aparatos de elevación" y 49 CFR 1910.179 "Elevación y grúas" Para la información completa.</p> <p>copias de A.S.M.E. B30.20 Se pueden obtener en <b>American Society of Mechanical Engineers</b> Order Department 1-800-THE-ASME.</p> <p>Copias de 49 CFR 1910.179 se pueden obtener en la oficina de publicaciones de OSHA (202)219-4667.</p>
<b>⚠ AVERTISSEMENT</b>
<b>INSPECTION DE GRUE</b>
<p>Cet élévateur a été construit en accord avec les interprétations d'A.S.M.E. B30.20. "Matériaux de sur-élévation" ainsi qu'avec les interprétations 49 CFR 1910.179 "sur-élévation et grues portiques."</p> <p>Avant l'utilisation initiale, tout élévateur nouveau, modifié, ou réparé doit être testé avec un chargement ne pouvant pas excéder 125% du taux de chargement dont il est capable. Au moins une fois par an, OSHA demande qu'une complète inspection de cette grue portique soit effectuée. Se reporter à l'article 49 CFR 1910.179 (J) (3). Une inspection visuelle devrait être effectuée périodiquement selon la fréquence d'utilisation de l'unité. Si cet élévateur montre une quelconque déficience, des corrections devraient immédiatement y être apportées ou celui-ci devrait être retiré du service.</p> <p>Lire avec attention le code A.S.M.E. B30.20 concernant les "Matériaux de sur-élévation" ainsi que les code 49 CFR 1910.179 "Sur-élévation et grues portiques" pour toute information complète.</p> <p>Des copies du code ASME B30.20 peuvent être obtenues au département de commande de l'"<b>American Society of Mechanical Engineers</b>". Au numéro 1-800-THE-ASME.</p> <p>Des copies du code 49 CFR 1910.179 peuvent être obtenues au bureau des publications OSHA au numéro (202)219-4667.</p>
<b>291</b>

<b>⚠ WARNING</b>
<u>Use with Caution</u>
<ul style="list-style-type: none"> <li>• Lock All Wheels In Perpendicular Position To One Another Before Loading</li> <li>• Check For Damage And Be Sure All Hardware Is Tight Before Each Use. Remove From Service And Repair Immediately If Necessary</li> <li>• Never Exceed Capacity Printed On I-Beam</li> <li>• Never Move Or Load Unless Both Height Adjustment Pins Are Fully Inserted</li> <li>• Never Cantilever Loads Off Of One End</li> <li>• Always Include Weight Of Hoist And Trolley When Calculating Load</li> <li>• Use On Level Concrete Or Equal Surface</li> </ul>
<b>⚠ AVISO</b>
<u>Use con Precaución</u>
<ul style="list-style-type: none"> <li>• Asegure Todas Las Ruedas En La Posición Perpendicular Antes De Cargar La Unidad.</li> <li>• Compruebe por daños y asegure que toda La Ferreteria Está Sujeta Antes De Cada Uso. Retire Del Servicio Y Repare Inmediatamente Si Es Necesario.</li> <li>• Nunca Exceda La Capacidad Impresa En La Viga I</li> <li>• Nunca Mueva O Cargue La Unidad A No Ser Que Ambos Pasadores De Ajuste De Altura Esten Completamente Insertos.</li> <li>• Nunca Deje Que La Carga Sobresalga En Un Solo Extremo.</li> <li>• Siempre Incluya El Peso De La Grúa Y La Carretilla Cuando Se Calcule La Carga.</li> <li>• Use En Cemento A Nivel O En Una Superficie Equivalente.</li> </ul>
<b>⚠ AVERTISSEMENT</b>
<u>Utiliser Avec Prudence</u>
<ul style="list-style-type: none"> <li>• Bloquer Chaque Roue En Position Perpendiculaire À Une Autre Avant De Charger.</li> <li>• Contrôler Tout Damage Et S'assurer Que Tout Le Matériel Soit Bien Serré Avant Chaque Utilisation. Retirer Du Service Et Réparer Immédiatement Si Nécessaire.</li> <li>• Ne Jamais Excéder La Capacité Imprimée Sur La Poutre.</li> <li>• Ne Jamais Déplacer Ou Charger Sans Que Les Deux Goupilles D'Ajustement De Hauteur Ne Soient Complètement Insérées.</li> <li>• Ne Jamais Cantilever Les Charges D'une Des Extrémités.</li> <li>• Toujours Inclure Le Poids De Levage Et De Charriage Pour Calculer La Charge.</li> <li>• Utiliser Sur Un Ciment À Niveau Ou Sur Une Surface Équivalente.</li> </ul>
<b>256</b>

<b>STATIC CAPACITY</b>
<p>2999 North Wayne Street Angola, IN 46703 USA (219) 665-7586</p>

<p>*** <b>STATIC CAPACITY</b> ***</p>
<p>2999 North Wayne Street Angola, Indiana 46703 USA Phone (219) 665-7586</p>

<b>STATIC CAPACITY</b>
<p>2999 North Wayne Street Angola, IN 46703 USA (219) 665-7586</p>

③